

# Hive Mini Controller



## Installation Guide

**The PassiveLogic Hive Mini® controller, paired with our modular Cell® I/O devices, handles remote equipment control and extends the reach of the PassiveLogic Hive™ autonomous building ecosystem.**

The Hive Mini can be deployed anywhere, avoiding the need to home-run wires. It supports universal software-defined input terminals, relays, power control, and more, by mixing and matching with our Cell I/O module types. The Mini includes automated I/O testing, as well as industrial networking with a 4-port Ethernet switch. The built-in differential pressure sensor enables VAV and AHU control applications by taking measurements such as airflow, filter status, and static pressure.

A Hive Mini controller is designed to support multiple IP protocols on its own, and adding a PassiveLogic Multi™ Cell module provides additional protocols. Built-in power monitoring enables continuous commissioning, with LEDs indicating status on each Cell terminal.

Use the Hive Mini for millions of remote building control applications, including but not limited to:

- Valves and damper actuators
- Fan coil units
- Sensor network applications
- Pressure and humidity transducers
- IoT device networks
- AC and DC motors
- RTUs and AHUs
- VAV and VRF systems

...and any other remote I/O applications.

The Hive Mini automatically joins our self-healing private network with the PassiveLogic Hive controller and PassiveLogic Sense® devices. As an enhanced wireless mesh gateway, the Hive Mini securely connects PassiveLogic wireless devices across a large area.



# Specifications

## Network

Wireless	Bluetooth range: Up to 100 ft (30 m)
Ethernet	4-port industrial switch (10/100MB), private network

## Connectivity Options

Protocols	BACnet/IP, Modbus TCP
Protocols w/Multi Cell	1-Wire protocol
Wireless antenna	SMA-compatible antenna included

## Onboard Sensing

Differential pressure sensor	<ul style="list-style-type: none"> <li>Range: +/- 500 Pa</li> <li>Accuracy: 1.5% across full range (+/- 15 Pa)</li> <li>Tubing: Supports 1/4 inch (6.35 mm), 1/16 inch (1.59 mm) wall thickness, plenum-rated 1219 FR (94V-2)</li> </ul>
------------------------------	--

## Cell Module Bays

2 Cell® module bays (compatible with these PassiveLogic Cell modules)

Multi™ Cell module*	6 multi-function terminals, universal software-defined I/O
Relay™ Cell module*	3 single-pole, single-throw, normally open relays

\* See Hive and Cell documentation for specs

## Powering the Hive Mini

Power draw	Up to 2A @ 24VAC nominal: Use ≥50VA supply
Input voltage	24VAC, connector accepts 12-20 AWG

## Environmental Operating Conditions

Operating temperature	14 to 122°F (-10 to 50°C)
Storage temperature	-4 to 122°F (-20 to 50°C)

## Mechanical

Height   Width   Depth (excluding antenna)	4.63 in (117.72 mm)   5.91 in (150.2 mm)   1.82 in (46.29 mm)
Weight	6.70 oz (190 g)
Surface mount	Use fasteners appropriate for the surface
Operating clearances	<ul style="list-style-type: none"> <li>Top: 1.5 in (38.1 mm), for dP tubing bend radius</li> <li>Bottom: 2.5 in (63.5 mm), for removing Cell modules</li> </ul>



## Dimensions

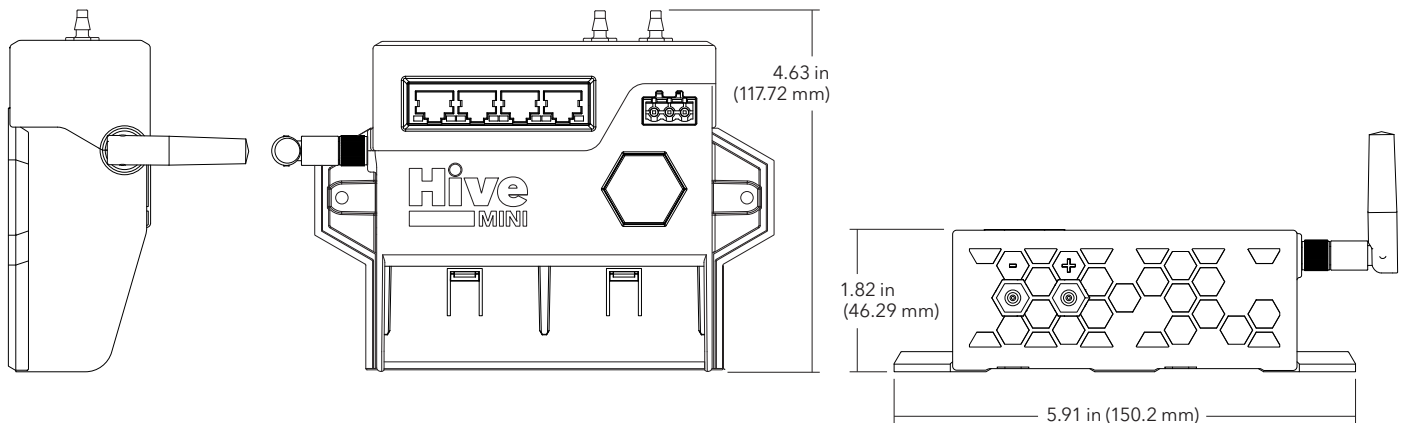

# Installation

## Mounting options

Be sure the Hive Mini is protected from the elements and has adequate ventilation in the install location. Mounting options include the following:

- Surfaces such as walls or ceilings
- Ductwork
- Inside devices like a VAV box, RTU, fan coil unit, unit ventilator, or other weather-protected enclosure
- Inside a control panel

Metal enclosures may require an antenna extender cable for adequate signal strength.

## Tools and materials

- Screwdriver, measuring tape, appropriate fasteners
- Included power terminal connector
- Included SMA-compatible antenna
- Tubing, if using dP airflow applications
- (Optional, not included) antenna extension cable

## Wiring

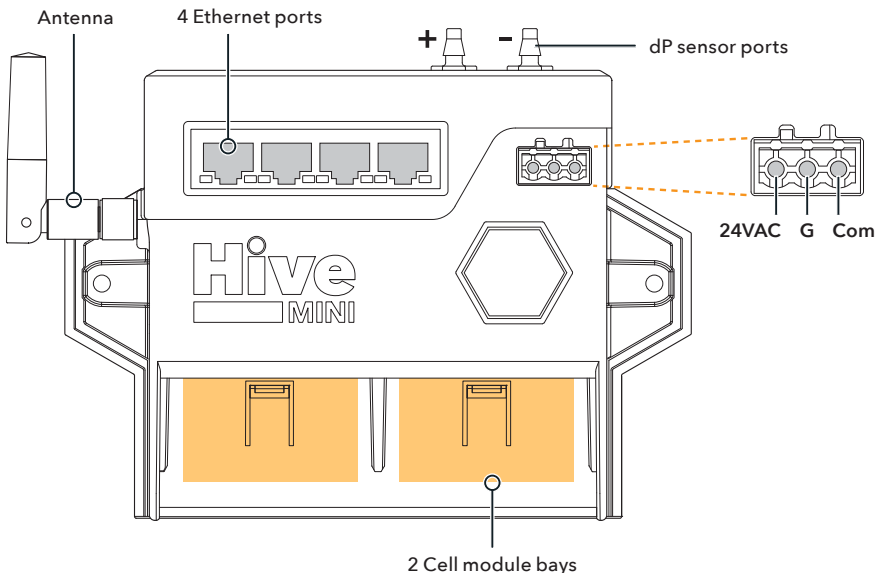

## Installing the Hive Mini controller

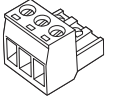
1. Make sure wires and dP tubing have been pulled to the install location.
2. Attach the included antenna to the device by screwing it on. If the Hive Mini is enclosed in metal, you may need to use an antenna extension cable to mount the antenna in a more optimal position.
3. Mark the drilling location, using the mounting holes on the sides of the device as a template. Fasten the device with appropriate fasteners.
4. Attach the included connector in the front. 
5. Connect power and Ethernet. (See "Wiring" below.)
6. If using dP applications, connect the air flow pickup tubing to the ports on the controller.
  - Connect the high pressure or upstream tube to the (+) port.
  - Connect the low pressure or downstream tube to the (-) port.

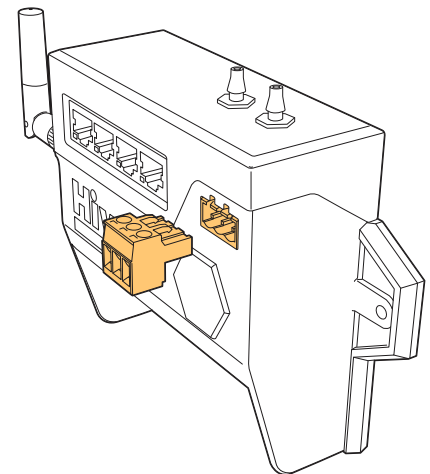

**⚠ WARNING:** This is a Class II electrical product. Use a Class II transformer to power the Hive Mini controller. The transformer should be rated to include the controlled equipment if the power source is shared.

If the Hive Mini controller is installed inside a device or panel that also contains a transformer, ensure proper clearance and adequate ventilation.

If using a Relay Cell module with line voltage in the PassiveLogic Hive Mini, you must take proper precautions, install the Hive Mini in a rated enclosure, and turn off power to the equipment before working on it. The Hive Mini controller must be grounded. Email [info@passivelogic.com](mailto:info@passivelogic.com) for additional safety guides.

## PassiveLogic private network

Hive and Hive Mini controllers feature a built-in multi-port Ethernet switch and automatically create a private, stand-alone network. We support a ring topology to connect Hive and Hive Mini devices for maximum resiliency, enabling redundant communication paths for both wired and wireless systems.

Designed to be self-managed, it requires no IT expertise and keeps IoT devices securely isolated from the cloud network. Hives and Hive Minis also serve as distributed wireless access points for our Sense Nano and Touch sensors. When you connect multiple Hive devices within a single building, the system distributes the PassiveLogic computation engine across nodes, scaling effortlessly to handle larger or more complex structures.

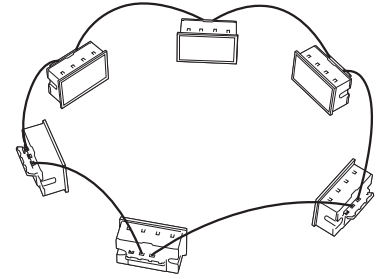

## Wiring examples

The Hive Mini controller is designed to handle millions of field controller and sensor applications. Terminal location for wires is flexible, as each Multi Cell terminal is for software-defined universal I/O, and Relay Cells have three dedicated relay pairs for switching up to 10A. The Hive Installation Guide has more information about Cell specifications and installation.

### Mechanical RTU control

Mini powered by RTU, built-in filter dP, temperature sensor, and CTs for 3-phase power monitoring

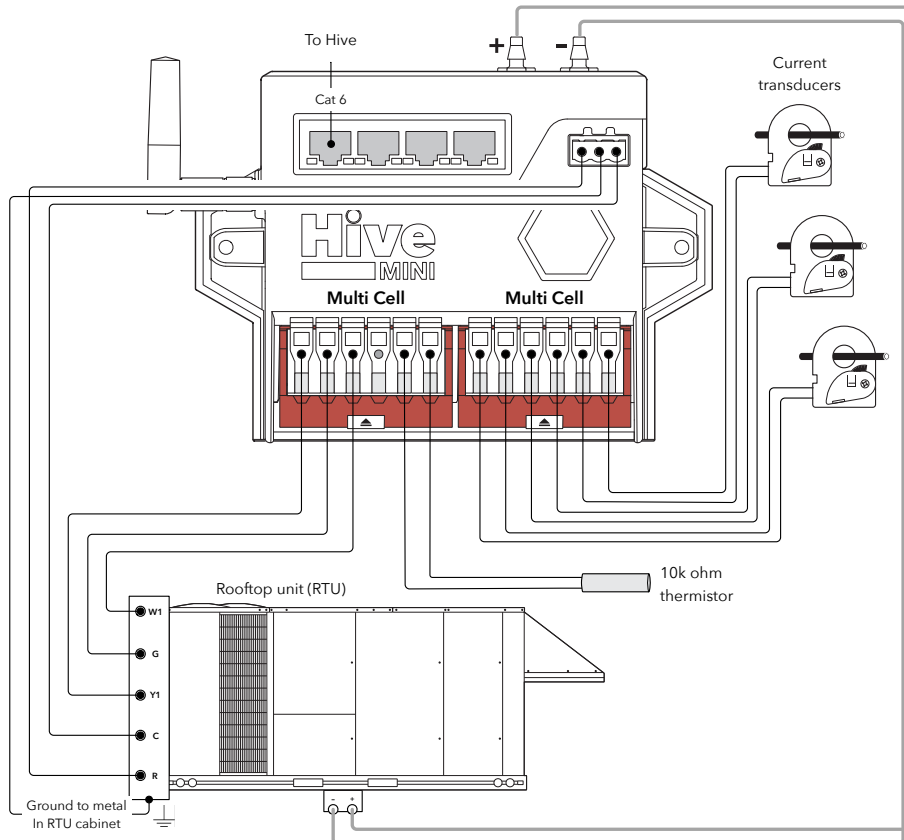

# VAV reheat control

Built-in flow sensor, damper actuator, hot water valve actuator, discharge air temperature sensor

